

FORM M55087

SCREEN ASSEMBLY
INSTALLATION PRECAUTION

CHEVROLET & TRUCKS
262-400 ENG. 8-CYL.

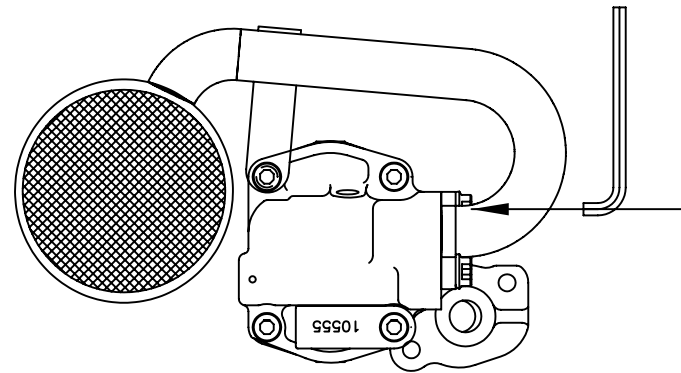

FOR EASE OF INSTALLING BOLTS
USE SHORTENED 5mm
ALLEN WRENCH
TO SECURE SCREEN.

*WE RECOMMEND USING
LOCTITE THREAD LOCKER
ON SCREEN BOLTS

FRONT

ENSAMBLE COLADOR
PRECAUCIONES DE INSTALACION

CHEVROLET Y CAMIONES
MOTOR 262-400 8 CILINDROS

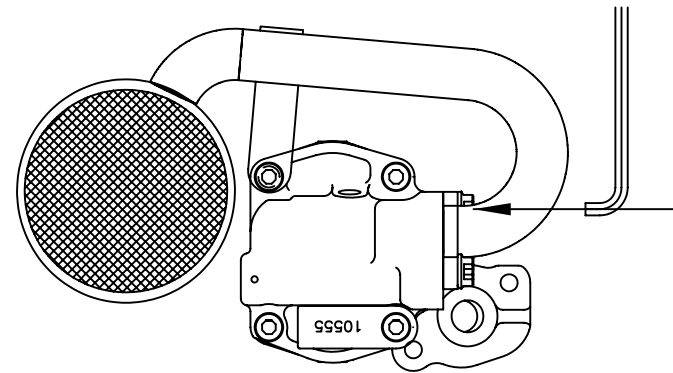



PARA FACILITAR LA INSTALACION DE
LOS TORNILLOS, RECOMENDAMOS
EMPLEAR UNA llAVE ALLEN
RECORTADA 5mm PARA ASEGURAR
EL COLADOR.

*RECOMENDAMOS EMPLEAR FIJADOR
DE TORNILLOS LOCTITE EN LOS
TORNILLOS DEL COLADOR.

BACK

SHEET SIZE - 4-1/4" x 5-1/2"
PAPER COLOR: YELLOW
PRINT FRONT AND BACK

	12/21/99	NEW RELEASE	2272
LTR.	DATE	REVISIONS	ECN #
MELLING TOOL COMPANY			
		ENGINE COMPONENTS PRODUCT ENGINEERING	
PROJ.	FORMS	SHT.	1 OF 1
DRAWN BY	COMPLETED	CHECKED	APPROVED
R.G.J.	9/24/98	RGJ	12/21/99
NAME			
SHEET-CAUTION INSTRUCTION			
PART NO.			
M55087			